

robot coupe®

Mini MP 170 V.V.

N° de série / Serial number
- 147 - - - - -

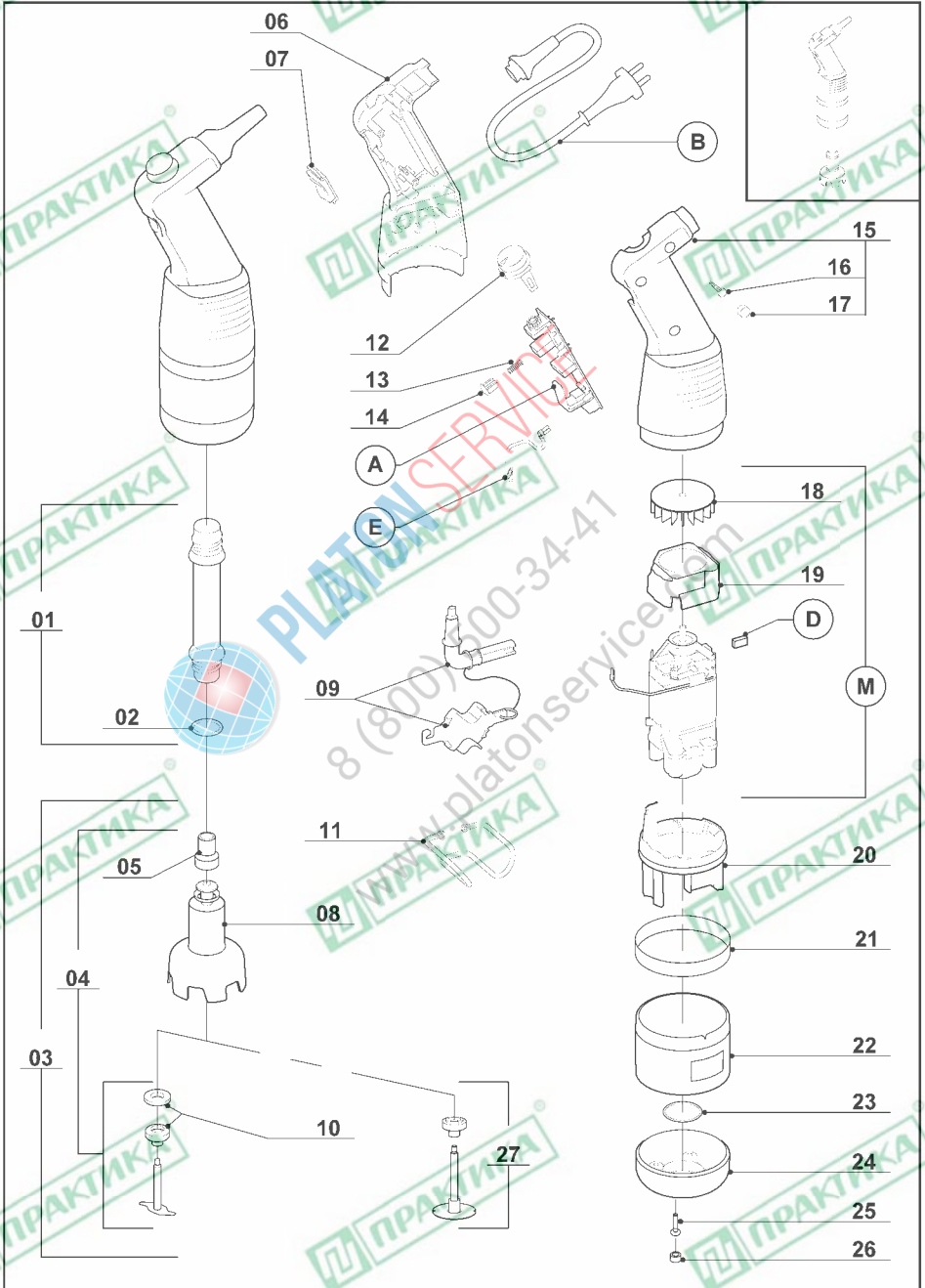

Index	Pièce / Part	Désignation	Description
1	104 207	PIED Mini MP 170 EQUIPE	Mini MP 170 FOOT
2	507 075	JOINT TORIQUE Ø 21.6 X 2.4	SEAL
3	39 053	ENS. CLOCHE COMPLETE MMP	COMPLETE MMP BELL COVER ASSEMBLY
4	39 054	ENS. COUTEAU MMP	MMP BLADE ASSEMBLY
5	104 312	CAGE D'ENTRAINEMENT EQUIPEE	DRIVING FRAME ASSEMBLY
6	39 055	ENS. ½ POIGNEE DROITE-CACHE VIS	RIGHT HANDLE-CAP SCREW ASSEMBLY
7	39 056	ENS. CAPUCHON-BOUTON-CACHE VIS	CAP KNOB-CAP SCREW ASSEMBLY
8	39 057	ENS. CLOCHE-BAGUE MMP	BELL COVER RING ASSEMBLY
9	39 058	ENSEMBLE OUTIL DEMONTAGE	TOOL ASSEMBLY
10	507 198	GARNITURE D'ETANCHEITE	SEAL RING
11	104 231	SUPPORT MURAL	RACK
12	39 059	ENS. BOUTON VARIATEUR EQU-CACHE VIS	VARIA SWITCH EQUIP-CAP SCREW ASSEMBLY
13	39 060	ENS. RESSORT-BOUTON-CACHE VIS	KNOB SPRING-CAP SCREW ASSEMBLY
14	39 061	ENS. BOUTON-CACHE VIS	KNOB-CAP SCREW ASSEMBLY
15	39 062	ENS. ½ POIGNEE G(CAPOT)+VIS+CACHE	L HANDLE (COVER)+SCREW+CAP ASSEMBLY
16	39 063	ENS. VIS 3x19-CACHE VIS	SCREW-CAP SCREW ASSEMBLY
17	39 064	ENS. CACHE VIS POIGNEE	HANDLE CAP SCREW ASSEMBLY
18	39 067	ENS. VENTILATEUR-CACHE VIS	VENTILATOR CAP SCREW ASSEMBLY
19	39 066	ENS. CONDUIT VENTILATEUR-CACHE VIS	VENTILATOR PIPE-CAP SCREW ASSEMBLY
20	39 065	ENS. BAGUE MOTEUR-CACHE VIS	MOTOR RING-CAP SCREW ASSEMBLY
21	39 068	ENS. VIROLE Mini MP 170 V.V.-CACHE VIS	FERRULE Mini MP 170 V.V.-CAP SCREW ASSEMBLY
22	39 070	ENS. VIROLE MOTEUR-CACHE VIS	MOTOR FERRULE MMP-CAP SCREW ASSEMBLY
23	39 158	ENS. JOINT MOTEUR-CACHE VIS	MOTOR O RING-CAP SCREW ASSEMBLY
24	39 159	ENS. CARTER ALU-CACHE VIS	ALUMINIUM CASING-CAP SCREW ASSEMBLY
25	39 161	ENS. VIS M 4x16-CACHE VIS	M 4x16 SCREW-CAP SCREW ASSEMBLY
26	39 162	ENS. CACHE VIS CARTER	CASING CAP SCREW ASSEMBLY
27	39 150	ENS. DISQUE EMULSIONNEUR PLEIN	DISC ASSEMBLY



8 (800) 500-34

www.platonservice.com

robot coupe**Mini MP 170 V.V.**N° de série / Serial number
- 147 - - - - -

Index	Pièce / Part	Désignation	/ Description			
A		PLATINE	/ CIRCUIT BOARD			
B		CABLE D'ALIMENTATION	/ POWER CORD			
D		CHARBON	/ BRUSH			
E		ENS. FILS	/ ELECTRICAL WRING			
M		MOTEUR	/ MOTOR			
Machine	Voltage	A	B	C	D	M
34 400	230/50/1	39 168	39 163	39 173	39 171	39 175
34 401 UK	240/50/1	39 168	39 165	39 173	39 171	39 175
34 402 Aust	240/50/1	39 168	39 166	39 173	39 171	39 175
34 404	220/60/1	39 169	39 163	39 173	39 171	39 175
34 405	120/60/1	39 170	39 167	39 174	39 172	39 176
34 406 Suisse	230/50/1	39 168	39 164	39 173	39 171	39 175



PLATON SERVICE
8 (800) 500-34-41
www.platonservice.com

robot coupe®

Mini MP 220 V.V.

N° de série / Serial number
- 148 - - - - -

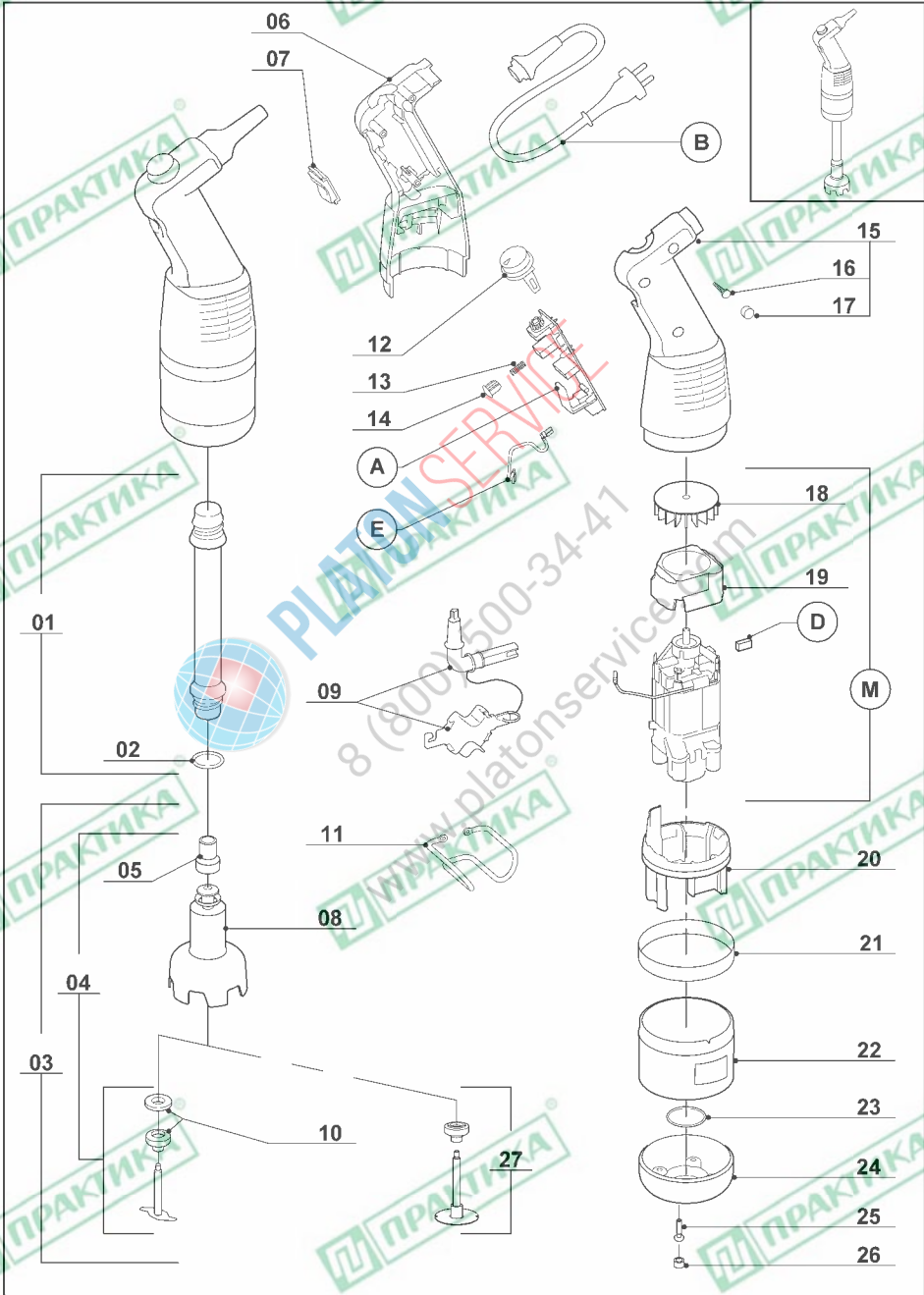

Index	Pièce / Part	Désignation	Description
1	104 211	PIED Mini MP 220 EQUIPE	Mini MP 220 FOOT
2	507 075	JOINT TORIQUE Ø 21,6 X 2,4	SEAL
3	39 053	ENS. CLOCHE COMPLETE MMP	COMPLETE MMP BELL COVER ASSEMBLY
4	39 054	ENS. COUTEAU MMP	MMP BLADE ASSEMBLY
5	104 312	CAGE D'ENTRAINEMENT EQUIPEE	DRIVING FRAME ASSEMBLY
6	39 055	ENS. ½ POIGNEE DROITE-CACHE VIS	RIGHT HANDLE-CAP SCREW ASSEMBLY
7	39 056	ENS. CAPUCHON-BOUTON-CACHE VIS	CAP KNOB-CAP SCREW ASSEMBLY
8	39 057	ENS. CLOCHE-BAGUE MMP	BELL COVER RING ASSEMBLY
9	39 058	ENSEMBLE OUTIL DEMONTAGE	TOOL ASSEMBLY
10	507 198	GARNITURE D'ETANCHEITE	SEAL RING
11	104 231	SUPPORT MURAL	RACK
12	39 059	ENS. BOUTON VARIATEUR EQU-CACHE VIS	VARIA SWITCH EQUIP-CAP SCREW ASSEMBLY
13	39 060	ENS. RESSORT-BOUTON-CACHE VIS	KNOB SPRING-CAP SCREW ASSEMBLY
14	39 061	ENS. BOUTON-CACHE VIS	KNOB-CAP SCREW ASSEMBLY
15	39 062	ENS. ½ POIGNEE G(CAPOT)+VIS+CACHE	L HANDLE (COVER)+SCREW+CAP ASSEMBLY
16	39 063	ENS. VIS 3x19-CACHE VIS	SCREW-CAP SCREW ASSEMBLY
17	39 064	ENS. CACHE VIS POIGNEE	HANDLE CAP SCREW ASSEMBLY
18	39 067	ENS. VENTILATEUR-CACHE VIS	VENTILATOR CAP SCREW ASSEMBLY
19	39 066	ENS. CONDUIT VENTILATEUR-CACHE VIS	VENTILATOR PIPE-CAP SCREW ASSEMBLY
20	39 065	ENS. BAGUE MOTEUR-CACHE VIS	MOTOR RING-CAP SCREW ASSEMBLY
21	39 069	ENS. VIROLE Mini MP 220 V.V.-CACHE VIS	FERRULE Mini MP 220 V.V.-CAP SCREW ASSEMBLY
22	39 070	ENS. VIROLE MOTEUR-CACHE VIS	MOTOR FERRULE MMP-CAP SCREW ASSEMBLY
23	39 158	ENS. JOINT MOTEUR-CACHE VIS	MOTOR O RING-CAP SCREW ASSEMBLY
24	39 159	ENS. CARTER ALU-CACHE VIS	ALUMINIUM CASING-CAP SCREW ASSEMBLY
25	39 161	ENS. VIS M 4x16-CACHE VIS	M 4x16 SCREW-CAP SCREW ASSEMBLY
26	39 162	ENS. CACHE VIS CARTER	CASING CAP SCREW ASSEMBLY
27	39 150	ENS. DISQUE EMULSIONNEUR PLEIN	DISC ASSEMBLY

robot coupe**Mini MP 220 V.V.**N° de série / Serial number
- 148 - - - - -

Index	Pièce / Part	Désignation	/ Description			
A		PLATINE	/ CIRCUIT BOARD			
B		CABLE D'ALIMENTATION	/ POWER CORD			
D		CHARBON	/ BRUSH			
E		ENS. FILS	/ ELECTRICAL WIRING			
M		MOTEUR	/ MOTOR			
Machine	Voltage	A	B	D	E	M
34 410	230/50/1	39 168	39 163	39 173	39 171	39 133
34 411 UK	240/50/1	39 168	39 165	39 173	39 171	39 133
34 412 Aust	240/50/1	39 168	39 166	39 173	39 171	39 133
34 414	220/60/1	39 169	39 163	39 173	39 171	39 133
34 415	120/60/1	39 170	39 167	39 174	39 172	39 134
34 416 Suisse	230/50/1	39 168	39 164	39 173	39 171	39 133



PLATON SERVICE
8 (800) 500-34-41
www.platonservice.com

robot coupe®

Mini MP 170 Combi

N° de série / Serial number
- 396 - - - - -

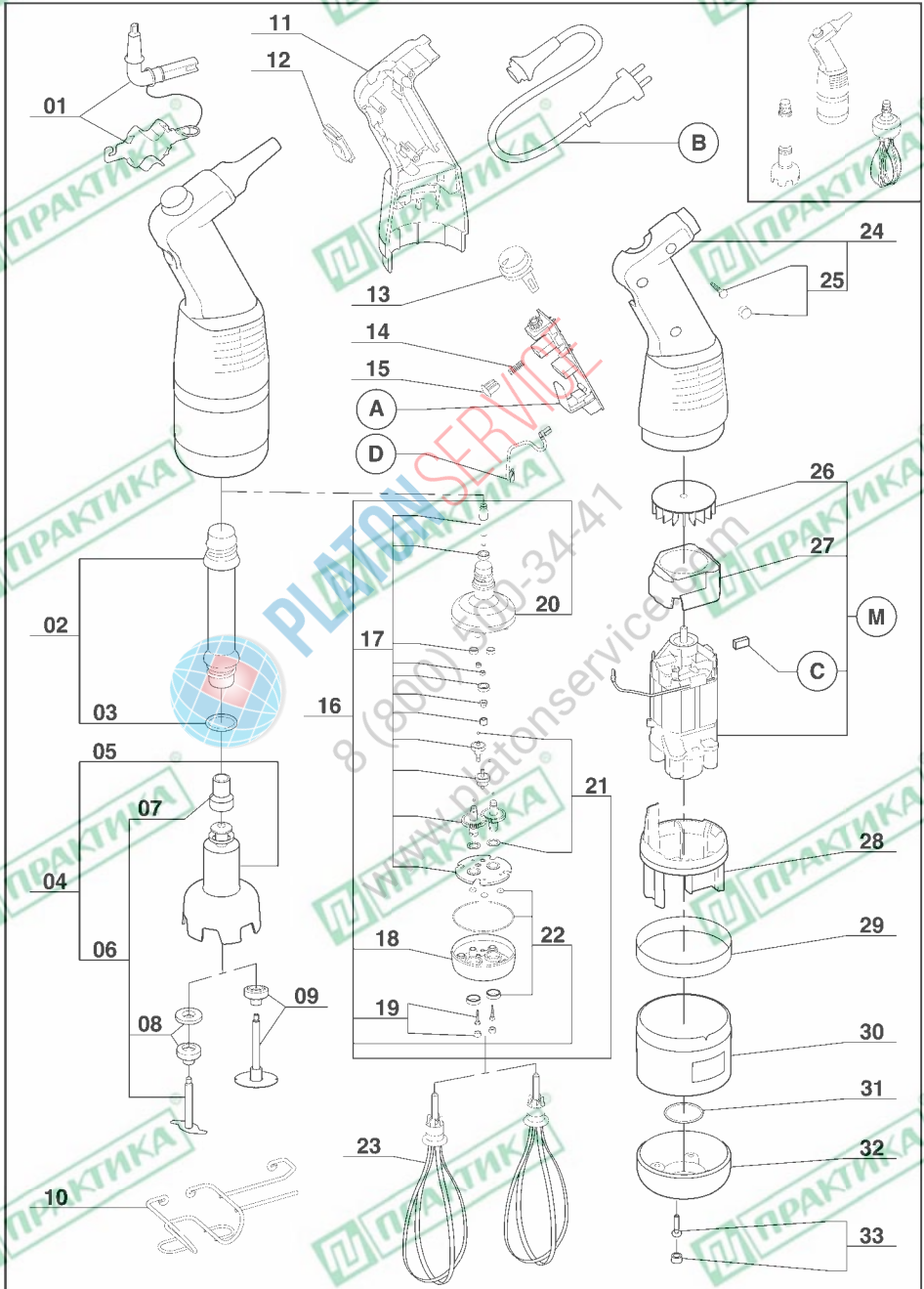

Index	Pièce / Part	Désignation	Description
01	39 058	ENSEMBLE OUTIL DEMONTAGE	TOOL ASSEMBLY
02	104 207	PIED Mini MP 170 EQUIPE	Mini MP 170 FOOT
03	507 075	JOINT TORIQUE Ø 21,6 X 2,4	SEAL
04	39 053	ENS. CLOCHE COMPLETE MMP	COMPLETE MMP BELL COVER ASSEMBLY
05	39 057	ENS. CLOCHE-BAGUE MMP	BELL COVER RING ASSEMBLY
06	39 054	ENS. COUTEAU MMP	MMP BLADE ASSEMBLY
07	104 312	CAGE D'ENTRAINEMENT EQUIPEE	DRIVING FRAME ASSEMBLY
08	507 198	GARNITURE D'ETANCHEITE	SEAL RING
09	39 150	ENS. DISQUE EMULSIONNEUR PLEIN	DISC ASSEMBLY
10	105 945	SUPPORT MURAL MMP Combi	RACK
11	39 055	ENS. ½ POIGNEE DROITE-CACHE VIS	RIGHT HANDLE-CAP SCREW ASSEMBLY
12	39 056	ENS. CAPUCHON-BOUTON-CACHE VIS	CAP KNOB-CAP SCREW ASSEMBLY
13	39 059	ENS. BOUTON VARIATEUR EQU-CACHE VIS	VARIA SWITCH EQUIP-CAP SCREW ASSEMBLY
14	39 060	ENS. RESSORT-BOUTON-CACHE VIS	KNOB SPRING-CAP SCREW ASSEMBLY
15	39 061	ENS. BOUTON-CACHE VIS	KNOB-CAP SCREW ASSEMBLY
16	105 156	BOITE FOUET MMP	WHIP BOX
17	39 500	ENS. PIGNON	GEARS ASSEMBLY
18	39 501	ENS. COQUE INFERIEURE	LOWER BODY ASSEMBLY
19	39 503	ENS. VIS-CACHE VIS	SREW – CAP SCREW ASSEMBLY
20	39 504	ENS. COQUE SUPERIEURE EQUIPEE BAGUES	UPPER BODY ASSEMBLY + RING
21	39 505	ENS. BILLE – RONDELLE D'USURE	BALLS – WEARING RING ASSEMBLY
22	39 506	ENS. JOINTS TORIQUES	SEALS ASSEMBLY
23	105 940	FOUET MMP	WHIP
24	39 062	ENS. ½ POIGNEE G(CAPOT)+VIS+CACHE	L HANDLE (COVER)+SCREW+CAP ASSEMBLY
25	39 063	ENS. VIS 3x19-CACHE VIS	SCREW-CAP SCREW ASSEMBLY
26	39 067	ENS. VENTILATEUR-CACHE VIS	VENTILATOR CAP SCREW ASSEMBLY
27	39 066	ENS. CONDUIT VENTILATEUR-CACHE VIS	VENTILATOR PIPE-CAP SCREW ASSEMBLY
28	39 065	ENS. BAGUE MOTEUR-CACHE VIS	MOTOR RING-CAP SCREW ASSEMBLY
29	39 068	ENS. VIROLE Mini MP 170 V.V.-CACHE VIS	FERRULE Mini MP 170 V.V.-CAP SCREW ASSEMBLY
30	39 070	ENS. VIROLE MOTEUR-CACHE VIS	MOTOR FERRULE MMP-CAP SCREW ASSEMBLY
31	39 158	ENS. JOINT MOTEUR-CACHE VIS	MOTOR O RING-CAP SCREW ASSEMBLY
32	39 159	ENS. CARTER ALU-CACHE VIS	ALUMINIUM CASING-CAP SCREW ASSEMBLY
33	39 161	ENS. VIS M 4x16-CACHE VIS	M 4x16 SCREW-CAP SCREW ASSEMBLY

Index	Désignation	Description
A	PLATINE	CIRCUIT BOARD
B	CABLE D'ALIMENTATION	POWER CORD
C	CHARBON	BRUSH
D	ENSEMBLE FILS	ELECTRICAL WIRING
M	MOTEUR	MOTOR

Machine	Voltage	A	B	C	D	M
34 420	230/50/1	39 168	39 163	39 173	39 171	39 175
34 421 UK	230/50/1	39 168	39 165	39 173	39 171	39 175
34 422 Aust	230/50/1	39 168	39 166	39 173	39 171	39 175
34 424	220/60/1	39 169	39 163	39 173	39 171	39 175
34 425	120/60/1	39 170	39 167	39 174	39 172	39 176
34 426 Suisse	230/50/1	39 168	39 164	39 173	39 171	39 175

robot coupe®

Mini MP 220 Combi

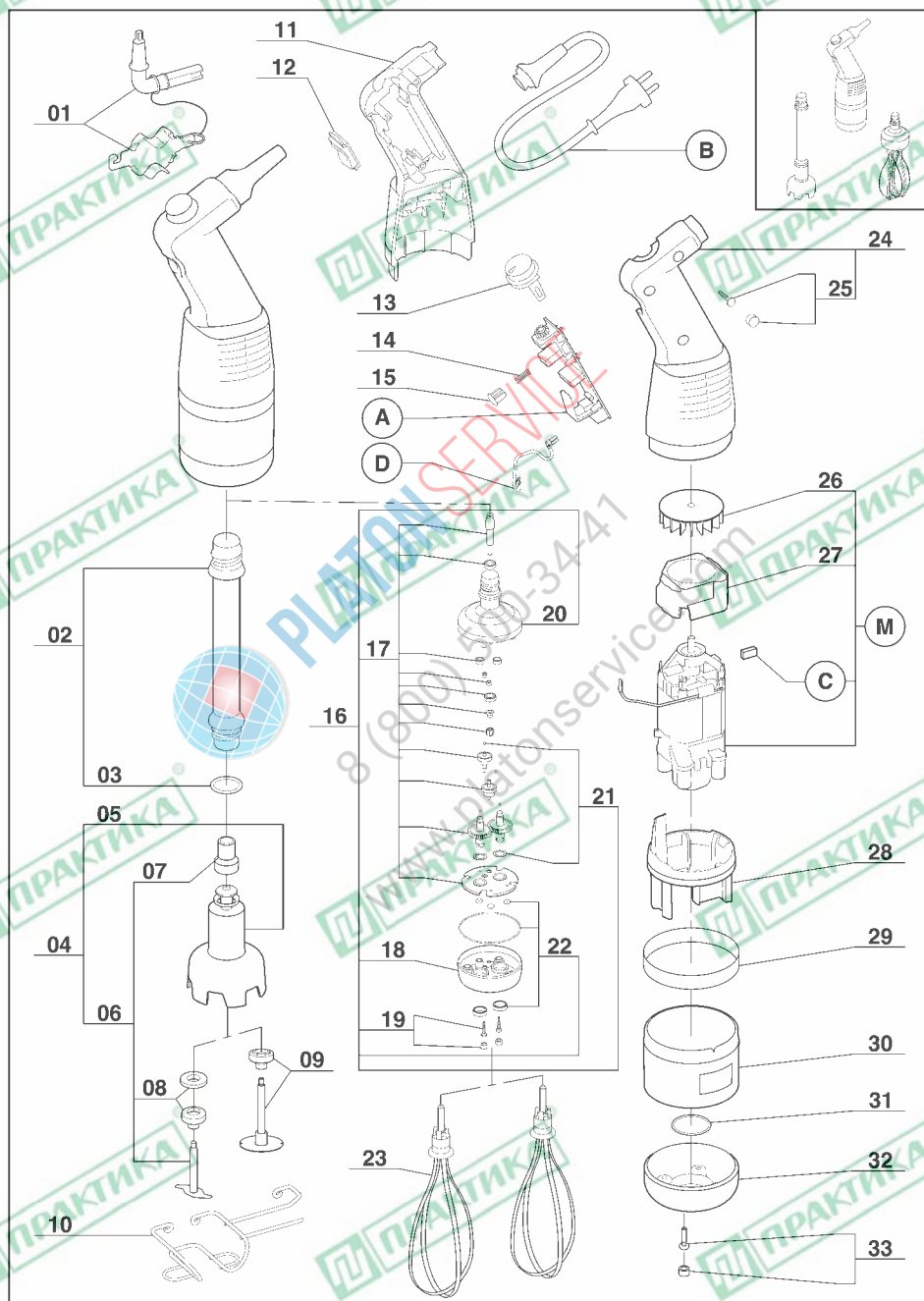
N° de série / Serial number
- 419 - - - - -

Index	Pièce / Part	Désignation	Description
01	39 058	ENSEMBLE OUTIL DEMONTAGE	TOOL ASSEMBLY
02	104 211	PIED Mini MP 220 EQUIPE	Mini MP 220 FOOT
03	507 075	JOINT TORIQUE Ø 21,6 X 2,4	SEAL
04	39 053	ENS. CLOCHE COMPLETE MMP	COMPLETE MMP BELL COVER ASSEMBLY
05	39 057	ENS. CLOCHE-BAGUE MMP	BELL COVER RING ASSEMBLY
06	39 054	ENS. COUTEAU MMP	MMP BLADE ASSEMBLY
07	104 312	CAGE D'ENTRAINEMENT EQUIPEE	DRIVING FRAME ASSEMBLY
08	507 198	GARNITURE D'ETANCHEITE	SEAL RING
09	39 150	ENS. DISQUE EMULSIONNEUR PLEIN	DISC ASSEMBLY
10	105 945	SUPPORT MURAL MMP Combi	RACK
11	39 055	ENS. 1/2 POIGNEE DROITE-CACHE VIS	RIGHT HANDLE-CAP SCREW ASSEMBLY
12	39 056	ENS. CAPUCHON-BOUTON-CACHE VIS	CAP KNOB-CAP SCREW ASSEMBLY
13	39 059	ENS. BOUTON VARIATEUR EQU-CACHE VIS	VARIA SWITCH EQUIP-CAP SCREW ASSEMBLY
14	39 060	ENS. RESSORT-BOUTON-CACHE VIS	KNOB SPRING-CAP SCREW ASSEMBLY
15	39 061	ENS. BOUTON-CACHE VIS	KNOB-CAP SCREW ASSEMBLY
16	105 156	BOITE FOUET MMP	WHIP BOX
17	39 500	ENS. PIGNON	GEARS ASSEMBLY
18	39 501	ENS. COQUE INFERIEURE	LOWER BODY ASSEMBLY
19	39 503	ENS. VIS-CACHE VIS	SREW - CAP SCREW ASSEMBLY
20	39 504	ENS. COQUE SUPERIEURE EQUIPEE BAGUES	UPPER BODY ASSEMBLY + RING
21	39 505	ENS. BILLE - RONDELLE D'USURE	BALLS - WEARING RING ASSEMBLY
22	39 506	ENS. JOINTS TORIQUES	SEALS ASSEMBLY
23	105 940	FOUET MMP	WHIP
24	39 062	ENS. 1/2 POIGNEE G(CAPOT)+VIS+CACHE	L HANDLE (COVER)-SCREW+CAP ASSEMBLY
25	39 063	ENS. VIS 3x19-CACHE VIS	SCREW-CAP SCREW ASSEMBLY
26	39 067	ENS. VENTILATEUR-CACHE VIS	VENTILATOR CAP SCREW ASSEMBLY
27	39 066	ENS. CONDUIT VENTILATEUR-CACHE VIS	VENTILATOR PIPE-CAP SCREW ASSEMBLY
28	39 065	ENS. BAGUE MOTEUR-CACHE VIS	MOTOR RING-CAP SCREW ASSEMBLY
29	39 069	ENS. VIROLE Mini MP 220 V.V.-CACHE VIS	FERRULE Mini MP 220 V.V.-CAP SCREW ASSEMBLY
30	39 070	ENS. VIROLE MOTEUR-CACHE VIS	MOTOR FERRULE MMP-CAP SCREW ASSEMBLY
31	39 158	ENS. JOINT MOTEUR-CACHE VIS	MOTOR O RING-CAP SCREW ASSEMBLY
32	39 159	ENS. CARTER ALU-CACHE VIS	ALUMINIUM CASING-CAP SCREW ASSEMBLY
33	39 161	ENS. VIS M 4x16-CACHE VIS	M 4x16 SCREW-CAP SCREW ASSEMBLY

Index	Désignation	Description
A	PLATINE	CIRCUIT BOARD
B	CABLE D'ALIMENTATION	POWER CORD
C	CHARBON	BRUSH
D	ENSEMBLE FILS	ELECTRICAL WIRING
M	MOTEUR	MOTOR

Machine	Voltage	A	B	C	D	M
34 430	230/50/1	39 168	39 163	39 173	39 171	39 133
34 431 UK	230/50/1	39 168	39 165	39 173	39 171	39 133
34 432 Aust	230/50/1	39 168	39 166	39 173	39 171	39 133
34 434	220/60/1	39 169	39 163	39 173	39 171	39 133
34 435	120/60/1	39 170	39 167	39 174	39 172	39 134
34 436 Suisse	230/50/1	39 168	39 164	39 173	39 171	39 133